

**Model:
HT0816B**

Hurricane Plus Blowers

OPERATION

SERVICE

PARTS

CARE



IMPORTANT SAFETY INSTRUCTIONS READ ALL INSTRUCTIONS BEFORE USING

WARNING

- To prevent personal injury or property damage, do not attempt to start engine until all assembly steps are complete and you have read and understand the safety and operating instructions in this manual.
- Under California law, and under laws of several other states, you are not permitted to operation internal combustion's engine using hydrocarbon fuels on any forest covered, brush covered, or grass covered land, or on land with grain, hay, or other flammable agricultural crop, without an engine spark arrester in continuous effective working order. The engine on your power equipment, like most outdoor power equipment, is an internal combustion engine that burns gasoline, a hydrocarbon fuel. Therefore, your power equipment must be quipped with a spark arrester muffler in continuous effective working order. The spark arrester must be attached to the engine exhaust system in such a manner that flames or heat from the system will not ignite flammable material. Failure of the owner/operator of the equipment to comply with this regulation is a misdemeanor under California law, and may also be a violation of other state and/or federal regulations, laws, ordinances, or codes. Contact your local fire marshal or forest service for specific information about what regulations apply in your area.
- Wear approved safety glasses when operating this equipment. The operation of any powered machine can result in foreign objects being thrown by high-speed rotating parts.
- Wear work gloves, sturdy footwear, and hearing protection when operating this equipment.
- Remove hearing protection and watch for traffic when operating near, or when crossing roadways.
- Before inspecting or servicing any part of equipment, shut off engine, disconnect spark plug wire from spark plug, and make sure that all moving parts have come to a complete stop. Be aware that rotating blades slow down gradually after engine is shut off.
- Exercise extreme caution on slopes and avoid excessively steep slopes.
- Never leave equipment unattended when engine is running. Shut off engine and disconnect spark plug wire from spark plug before leaving equipment. Turn off fuel shut-off if equipped.
- Do not vacuum any burning or smoldering materials such as cigars, cigarettes, ashes, or cinders.
- Do not vacuum areas that have been recently treated with fertilizers, pesticides, or herbicides. Follow chemical manufacturer's safety instructions regarding contact with treated areas.
- Do not vacuum flammable liquids such as gasoline, kerosene, diesel fuel, paint thinner, etc.
- Do not operate this equipment on a paved, gravel, or hard surface unless the collection bag is installed. Discharged material may bounce from a hard surface.
- Never pick up or carry equipment while the engine is running.
- Walk, never run.
- Never allow children or untrained adults to operate this equipment.
- Keep the area of operation clear of all persons, particularly small children, and pets. Keep bystanders at least 25 feet away from the area of operation.

- Do not run engine in an enclosed area. Engine exhaust contains carbon monoxide gas, a deadly poison that is odorless, colorless, and tasteless.
- Do not operate this equipment near buildings, windows, or air conditioners.
- Do not allow hands or any other part of the body or clothing inside the vacuum inlet.
- Do not start engine or operate this equipment with any safety guards or housing removed.
- Operate machine in daylight or good artificial light.
- Do not change the engine governor settings or overspeed the engine.

DANGER

Gasoline is highly flammable and its vapors are explosive. To prevent personal injury or property damage:

- Do not add fuel if engine is running or still hot from recent operation. Allow engine to cool for at least three minutes.
- Do not fill fuel tank indoors. After filling, wipe up any spills and move away from gasoline fumes before starting engine.
- Do not allow open flame, matches, or smoking in area.
- Fill fuel tank with fresh, clean unleaded regular automotive gasoline, (leaded regular and unleaded or leaded premium grades of gasoline are acceptable substitutes).
- Do not mix oil with gasoline.
- Clean the area around the fuel fill cap and remove the cap from the fuel tank. Insert a clean funnel into the fuel tank.
- Fill the tank to 1/2 inch below the bottom of the filter neck to provide space for any fuel expansion.
- Reinstall the fuel fill cap securely and wipe up any spilled gasoline.
- Store fuel in containers specifically designed for these purposes.
- Replace faulty silencers or mufflers and muffler guards.
- Before using, visually inspect to see that the blade and blade bolts are not worn or damaged and, if needed, replace in sets.
- Do not start the engine when standing in front of the discharge chute.
- Drain fuel outdoors.

SAVE THESE INSTRUCTIONS

SAFETY DECALS

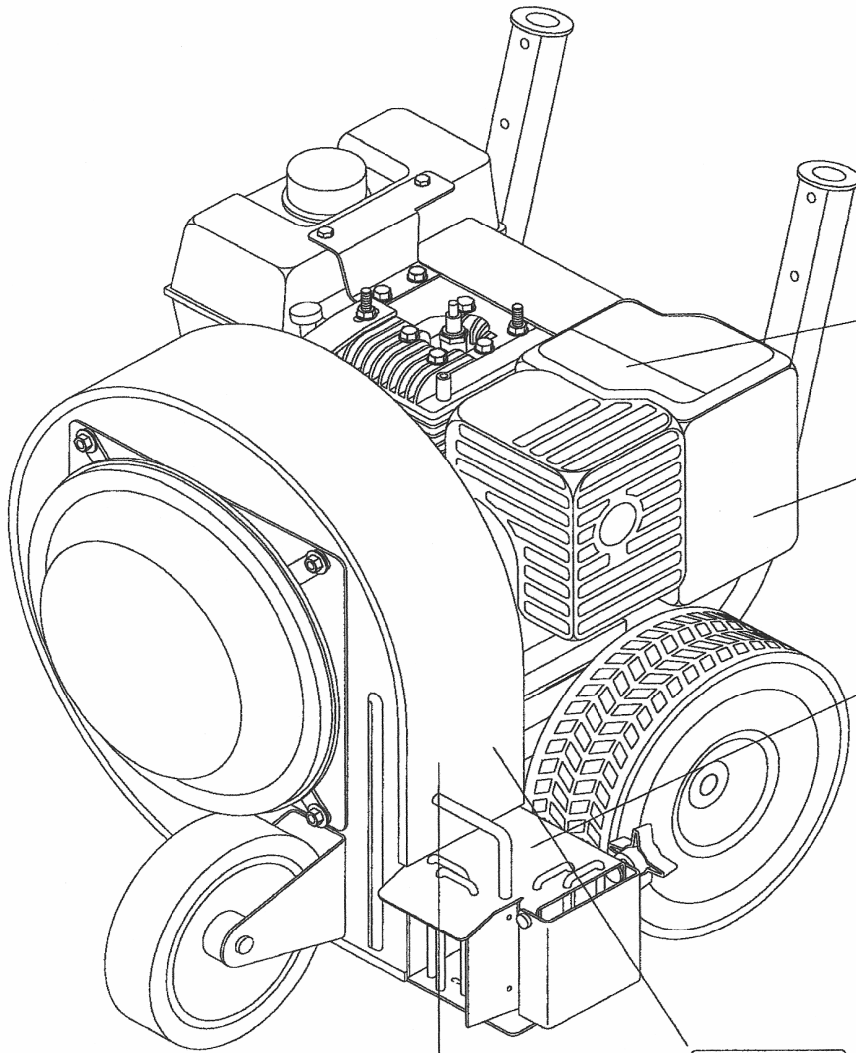

WARNING
TO AVOID SERIOUS INJURY:
* TO AVOID SEVERE BURNS, DO NOT TOUCH
MUFFLER OR ADJACENT AREAS.
* TO AVOID A FIRE HAZARD, KEEP LEAVES, GRASS,
AND OTHER COMBUSTIBLE MATERIALS AWAY FROM
ENGINE AND MUFFLER. T12814

P/N: 715314



P/N: 715321



P/N: 715217

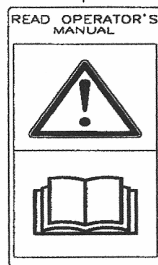

P/N: 715051



P/N: 715301

ASSEMBLY INSTRUCTIONS HT0816B

FRONT WHEEL ASSEMBLY

No front wheel assembly required.

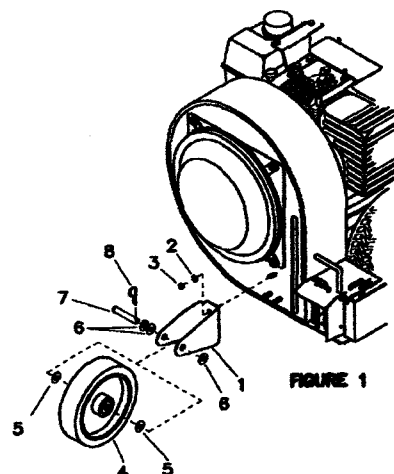

HANDLE ASSEMBLY

Install handle assembly to blower, place rubber shim (1) under handle strut (2) and place 5/16-18 x 2 bolt (4) and 3/8 washer (3) into holes in handle strut (2) and through frame (5) and tighten (not all the way) with 5/16 washer (6) and 5/16-18 nyloc nut (7). Place handle (8) into handle struts (2) and align holes in handle (8) and struts (2). Place 5/16-18 x 2 bolt (4) and 3/8 washer (3) into strut (2) and handle (8), as shown, and tighten with 3/8 washer (3) and 5/16-18 nyloc nut (7) Tighten bolts on strut frame at this time.

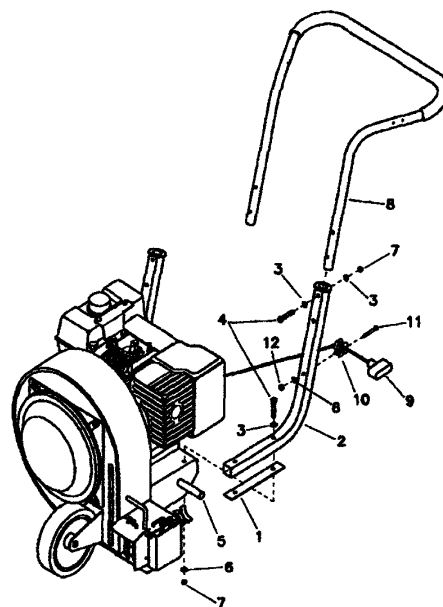

Throttle Assembly

No assembly required.

HT0816B

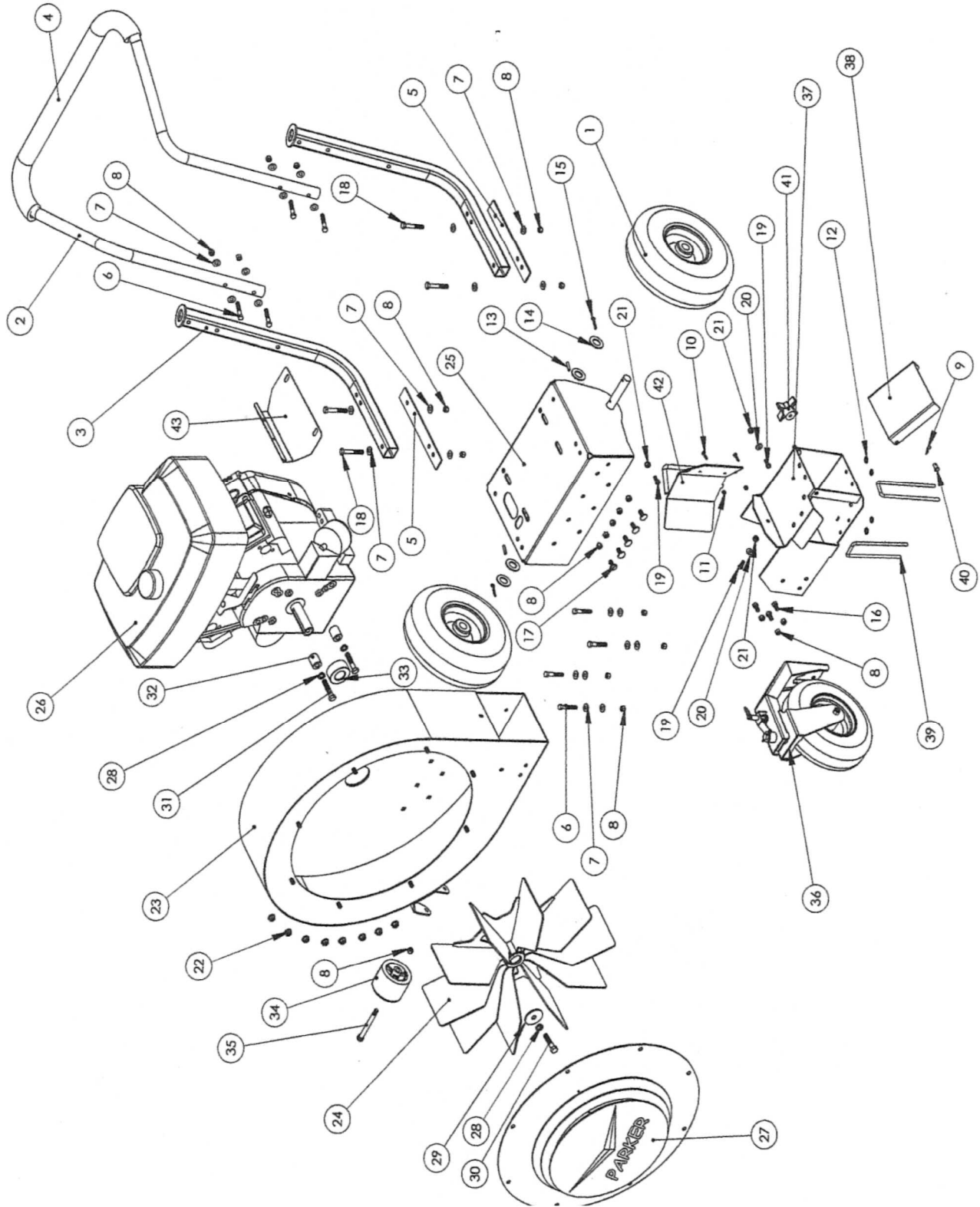

HT0816B

ITEM NO.	PART NUMBER	DESCRIPTION	QTY.
1	360140	WHEEL PNEU. ¾ BORE	2
2	360109PTD	HANDLE BLOWER- PAINTED	1
3	360112	WELD TUBE LOWER HANDLE	2
4	360108	SLEEVE HANDLE	1
5	360129	RUBBER SHIMS	2
6	713030	BLT-HH 5/6-18 X 1 ¾ #5	8
7	711506	WASHER FLAT 5/16	24
8	711374	NUT - -NYLOC 5/16 – 18	21
9	711808	PIN COTTER # 13	1
10	710232	SCREW 10-32 X ¾	2
11	711350	NUT – NYLOC 10-32	2
12	75-89-A	NUT SPEED ¼	4
13	67-521-A	PIN – ROLL 3/16 X 1	2
14	711512	WSHR FLT. .75 X 1.37 X .08	4
15	711809	PIN COTTER 1/8 X 1	2
16	713026	BLT- HH 5/16 – 18 X 3/4 #5	3
17	712102	BLT– CARRIAGE 5/16 X 3/4	7
18	713031	BLT– HH 5/16 – 18 X 2 #5	4
19	713001	BLT – HH ¼ - 20 X .62	3
20	711505	WASHER FLAT ¼	2
21	711373	NUT – NYLOC ¼ - 20	3
22	711374	NUT-NYLOC 5/16 - 18	8
23	360541	BLOWER HOUSING 16 Hp	1
24	360536	FAN ASSEMBLY 16 Hp	1
25	360500	FRAME WELD ASSEMBLY 16 Hp	1
26	360216	ENGINE 16 Hp VANGUARD	1
27	SA-1072-B	FAN COVER ASSEMBLY	1
28	711546	WASHER-HELICAL 3/8	3
29	82-138-B-3	WASHER	1
30	713103	BLT – HH 3/8 – 24 X1.75 #5	1
31	713045	BLT – HH 3/8 -16 X 1.75 #5	2
32	82-24-B	SPACER .38 X .875 X 1.040	2
33	73-415-A	SPACER 1.03 X 2 X .875	1
34	76-58-0	ROLLER	1
35	76-202-A	SHOLDER BOLT SOCKET 3/8 X 2 ¾	1
36	SA-50 1	9" PNEU. SWIVEL CASTER ASSY.	1
37	360531	CHUTE WELD ASSEMBLY	1
38	360532	CHUTE FLAP	1
39	360534	SAFETY GUARD 16 Hp	2
40	831889	PIN CLEVIS 5/16 X ½	2
41	350139	KNOB 5/16 THREAD	1
42	360533	CHUTE AIR DEFLECTOR	1
43	360552	HEAT SHIELD 16 Hp	1
44	170051	SPRNG SWITCH CHUTE DOOR * Not Shown*	1
45	360526	LEVER CHUTE DOOR ** Not Shown**	1

Caster Assy.

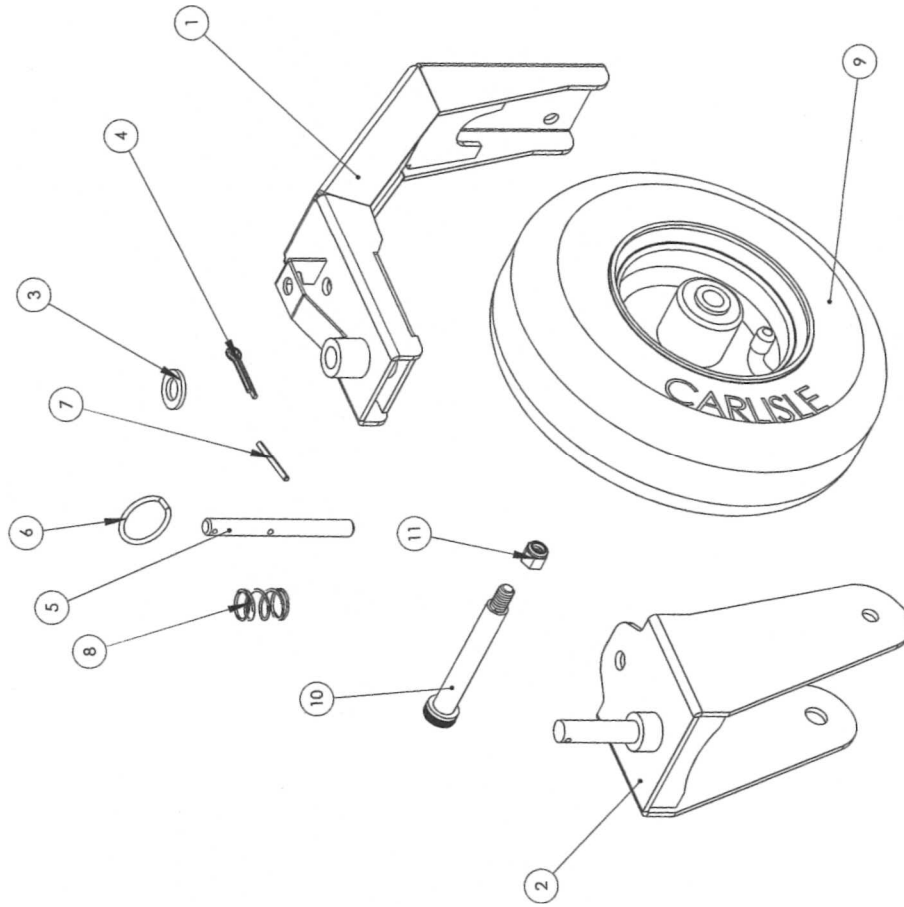

Complete Assembly Part # SA-501

Caster Assy.

Item	PART	DESCRIPTION	QTY.
1	SA-501-B	ARM WELD SWIVEL ASSY.	1
2	SA-501-A	WHEEL BRACKET ASSY.	1
3	711509	WASHER FLT. ½ STEEL. ZINC	1
4	711809	PIN COTTER 1/8 X 1	1
5	360608	PIN 3/8 ROUND	1
6	711621	KEY RING 1 1/8 FOR SWIVEL	1
7	360609	PIN ROLL .125 x 1 3/4	1
8	170051	SPRING SWITCH	1
9	360157	TIRE PNEU. 9 X 2.50	1
10	712115	BOLT SHDR. 1/2/ X 3.25	1
11	711380	NUT NYLOC 3/8 - 16	1

LIMITED WARRANTY

The Parker Sweeper Company warrants to the original purchaser/user that this product is free from defects in workmanship and materials under normal use and service for a period of two years from date of purchase. In addition, Parker Sweeper Company will, at its option, honor labor warranty claims for the first 12 months from date of sale, provided such claims are submitted through and approved by factory authorized repair stations. Parker Sweeper Company will, at its option, repair or replace without charge, except for transportation costs, parts that fail under normal use and service when operated and maintained in accordance with the applicable operation and instruction manuals.

This warranty does not apply to normal wear, or to items whose life is dependent on their use and care, such as belts, cords, switches, hoses, rubber parts, electrical motor components or adjustments. Parts not manufactured by Parker Sweeper Company such as engines, batteries, battery chargers, hydraulic pumps, and tires are covered by and subject to the warranties and/or guarantees of their manufacturers. Please contact Parker Sweeper Company for procedures in warranty claims against these manufacturers.

Special warning to purchaser - Use of replacement filters and/or prefilters not manufactured by Parker Sweeper Company or its designated licensees, will void all warranties expressed or implied.

A potential health hazard exists without exact original equipment replacement.

All warranted items become the sole property of Parker Sweeper Company or its original manufacturer, whichever the case may be.

Parker Sweeper Company disclaims any implied warranty, including the warranty of merchantability and the warranty of fitness for a particular purpose. Parker Sweeper Company assumes no responsibility for any special, incidental or consequential damages.

This limited warranty is applicable only in the U.S.A. and Canada, and is extended only to the original user/purchaser of this product. Customers outside the U.S.A. and Canada should contact their local distributor for export warranty policies. Parker Sweeper Company is not responsible for costs or repairs performed by persons other than those specifically authorized by Parker Sweeper Company. This warranty does not apply to damage from transportation, alterations by unauthorized persons, misuse or abuse of the equipment, use of non-compatible chemicals, or damage to property, or loss of income due to malfunctions of the product.

If a difficulty develops with this machine, you should contact the dealer from whom it was purchased.

This warranty gives you specific legal rights, and you may have other rights which vary from state to state. Some states do not allow the exclusion or limitation of special, incidental or consequential damages, or limitations on how long an implied warranty lasts, so the above exclusions and limitations may not apply to you.



**Division of Kwik Products Inc.
3700 East Anne Street Phoenix, AZ 85040
Tel: 602 453-3950 Fax: 602-453453-3929
Web: www.parkersweeper.com**